

NETZSCH

Proven Excellence.



Grinding Systems

Product Overview, Technology and Application Areas

Pumps & Systems

Grinding Systems protect your installation

Universal Use

Grinding systems are used to effectively protect your complete installation including the pumping equipment. They ensure that over-size solids are reliably reduced to a pumpable size therefore safely avoiding the danger of blockages.

Grinders and macerators are designed for the most arduous of industrial applications to prevent pipe blockage and damage to downstream equipment by reliably reducing the size of solid matter in pumped media. The extensive selection of macerating systems provides an ideal solution for many industries and processes.

The robust design of the grinding systems from NETZSCH ensures a high performance coupled with trouble free operation.

Primary Applications

- Waste water treatment
- Agriculture
- Biogas plants
- Slaughterhouses and recycling plants
- Canning/tinning factories
- Industrial kitchens
- Sugar factories

Advantages

- Optimum price/performance ratio
- Low running costs through high operating efficiency
- High operational reliability
- Simple maintenance
- Comprehensive range of accessories available for almost every application
- Worldwide service network and weekend emergency support



... and are so easy to maintain:

FSIP® Full Service in Place

The Right Model for Every Application

M-Ovas® Cutting Plate Macerator

The special shape of the housing directs solid particles in the waste water towards the cutting plate, where they are held and chopped by the rotating blades.

N.Mac® Double Shaft Grinder

The double shaft grinders have been designed for applications where the medium contains large solid objects. These grinders are available in two different housing designs: the inline version for installation in pipelines and the channel version for installation into effluent channels.

Depending on the size reduction required there is a choice of different tooth combinations.

For maintenance these macerators do not have to be removed from the pipeline/from the channel: NETZSCH offers "Full Service in Place".

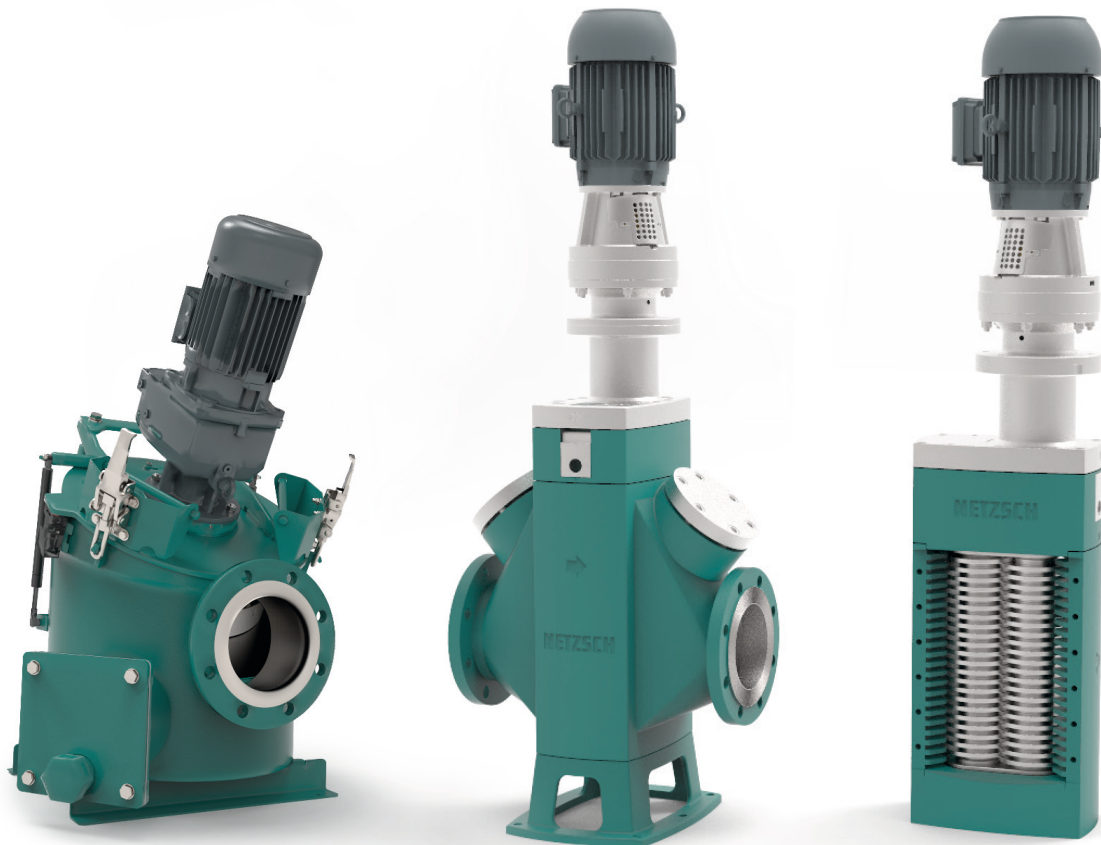

M-Ovas® cutting plate macerator, N.Mac® double shaft grinders in inline and channel version

M-Ovas[®]

CUTTING PLATE MACERATOR

The M-Ovas[®] macerator for coarse materials is ideally suited for use in waste water treatment plants where impurities in the medium reduce process reliability. The solids in the medium are reliably macerated or separated from the medium (e.g. stones), to prevent pipes getting blocked or damage to downstream equipment.

Broad range of applications

The M-Ovas[®] should preferably be used to macerate the following media:

- Fibers and solids in waste water
- Liquid manure
- Substrates

High flow rates

- Throughput rates of up to 300 m³/h with water

1 Housing

Hydrodynamic design with integrated stone trap for solids, and a clean-out port. The sediment can easily be removed by opening the cover plate. The housing is galvanized to ensure corrosion resistance. Available in stainless steel (optional).

2 Housing Cover

Cutting unit integrated into housing cover. A gas strut is fitted to the cover to assist opening.

2a This port allows for easy cleaning of solids in the stone trap.

3 Cutting Unit

The optimum performance of the cutting unit results from the spring support of the cutting plate. The cutting plate is made of wear resistant, hardened steel. Optimum cutting performance through cutting unit with a fixed cutting mechanism. Cutting head and cutting blades made from wear resistant hardened steel. The flywheel effect of the cutting head supports the cutting process and reduces the drive power. Easy exchange of cutting plate and cutting blades without disassembling the pipework. A manual adjustment is not necessary due to the pressure spring support.

Advantages

- Compact design with high throughput rate
- Simple, easy disassembly of the cutting plate
- Low energy requirement with high throughput rate
- Integrated separator vessel with separate cleaning and drainage aperture
- Effortless disposal of the sedimented materials through easy access
- Shaft sealing using mechanical seal with lubrication
- Particularly maintenance friendly
- Cutting plate usable on both sides
- Different perforated plates depending on the application
- Draining connection for easy liquid emptying

4 Shaft Seal

Single mechanical seal made of hard metal with oil quench to prevent product leakage.

5 Drive

The standard drive unit has reinforced bearings.

6 Inline Version

Product inlet and outlet are positioned on the same level. The M-Ovas® can be directly connected to a horizontal pipeline or to a NEMO® pump inlet where the flange is set at 90°.

7 Draining Connection

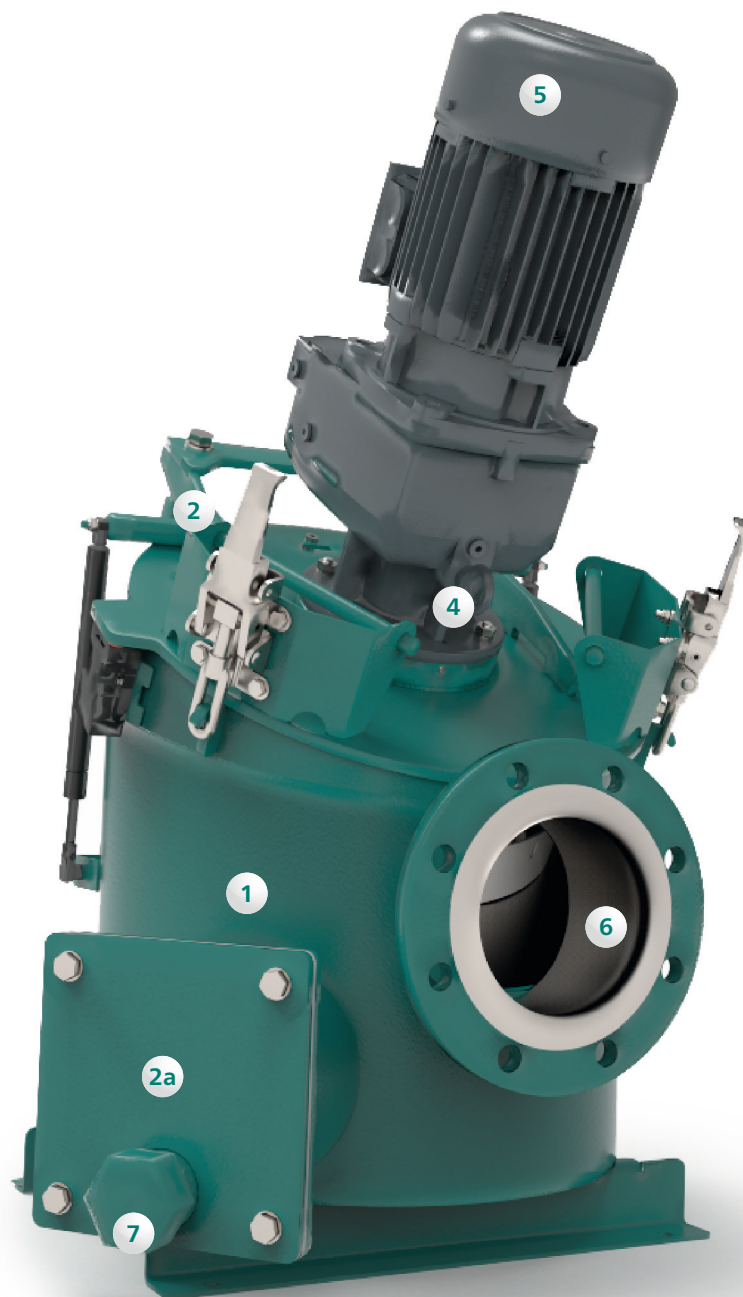

Functionality

With the cutting plate macerator the crushable parts are either pressed to the cutting plate or partially drawn into the holes of the cutting plate by the flow. Larger particles jam in front of the cutting plate and are crushed by the cutting head until they can be flushed through the openings of the cutting plate.

Wear resistance

The cutting plate consists of a wear-resistant special alloy, is hardened and finely polished on the contact surface to the cutter head.

The cutter head is made of steel with positively shaped carbide cutting edges. In case of wear the cutting plate can be turned.

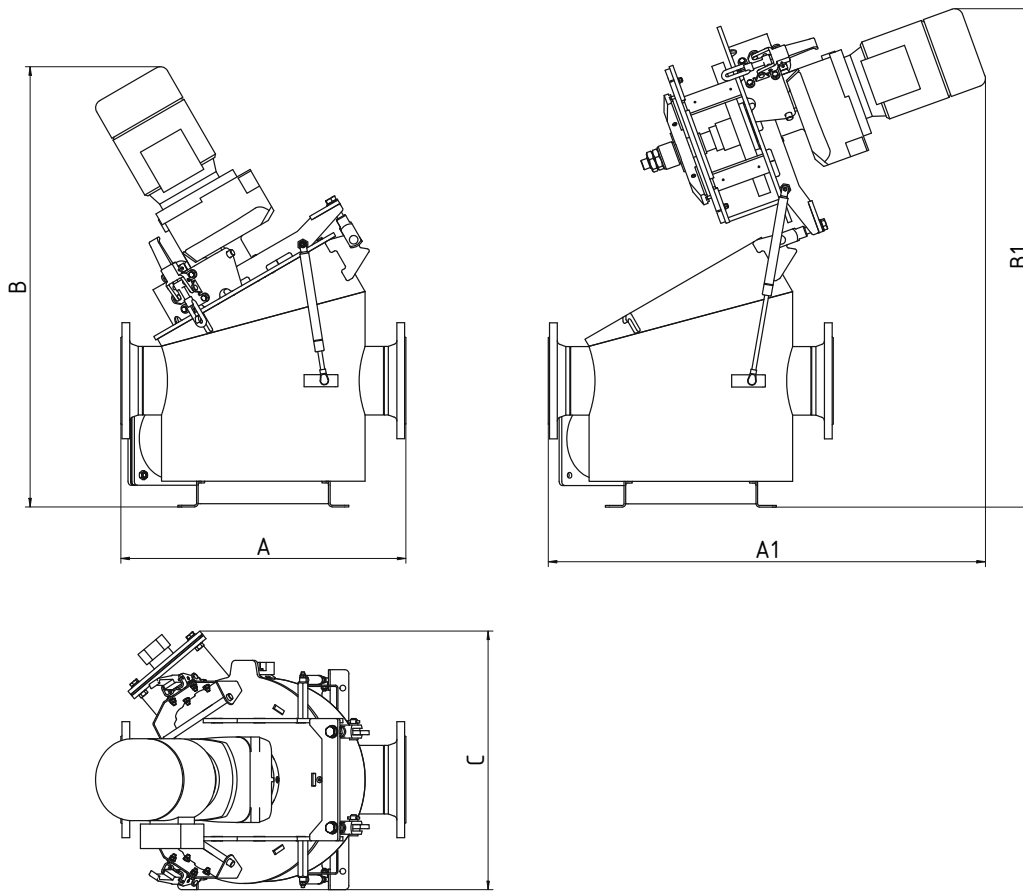

Flow rates und dimensions

Sizes	Flow rate (m ³ /h)	Pressure drop (bar)	Maximum pressure (bar)	Approximate weight (kg)	Flanges (ANSI/DIN)	Dimensions (mm)				
						A	A1	B	B1	C
S 2,2/50	50	0,05	1	120	100 PN16	500	790	840	850	400
S 4,0/300	300	0,12	1	195	150 PN16	700	1100	1080	1230	640

Combinations

MANY OPTIONS POSSIBLE

The medium with solid or fibrous parts is continuously sucked into the M-Ovas® by a self-priming NEMO® progressing cavity pump or TORNADO® rotary lobe pump arranged behind the macerator. The solids are crushed or remain in the stone trap below the cutting unit. This protects all downstream units.

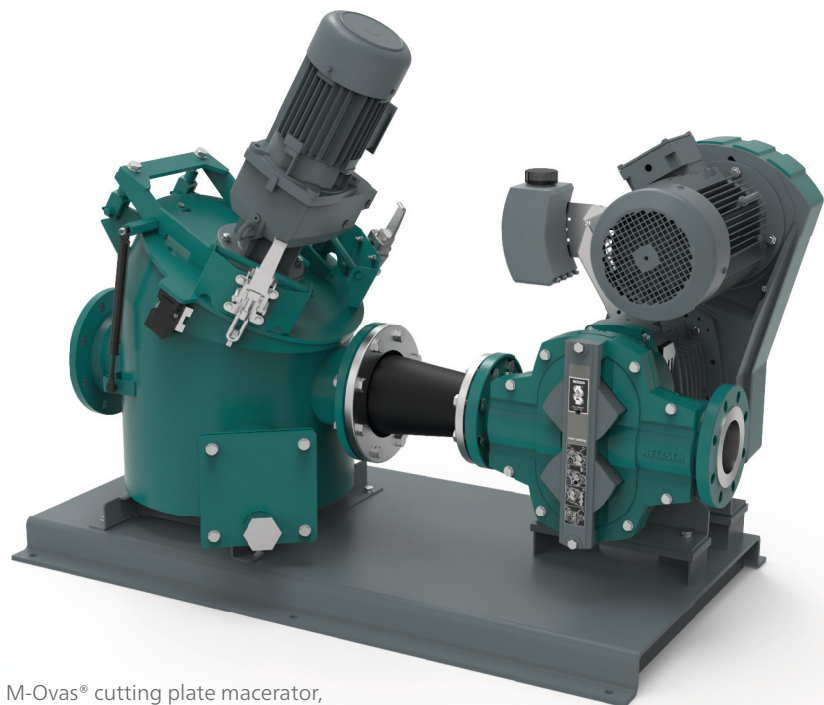

M-Ovas® cutting plate macerator, horizontally connected to a TORNADO® rotary lobe pump.

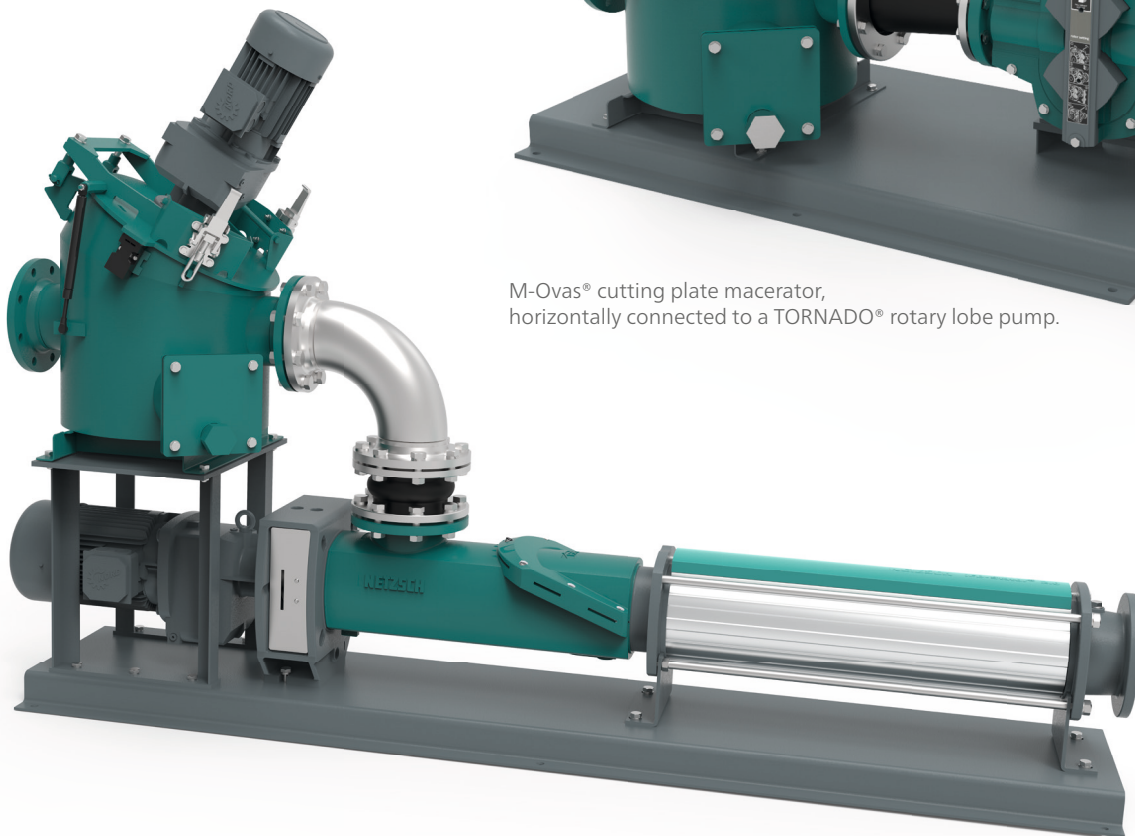

M-Ovas® cutting plate macerator connected to a NEMO® pump inlet with the flange set at 90°.

N.Mac[®] Inline

DOUBLE SHAFT GRINDER FOR

The double-shaft grinder N.Mac[®] is capable of fragmenting large and solid particles in liquid media. It is the ideal equipment to suit different applications such as wastewater treatment, substrates or food and fruit scraps for biogas plants. The inline housing allows installation in piping systems to protect downstream equipment, such as pumps.

Features

- Double shaft technology for size reduction of solid particles
- Energy efficient motors, from 2.2 - 4 kW
- Low speed of the cutters with high torque
- Standard cutter arrangement with 7/7 teeth
- Optional control unit with reverse direction of rotation in case of blockages

Your benefits

- Shock absorption system
- Mechanical seals with quench
- Optional cleaning comb for fibrous materials
- Cutting devices in cartridge system
- Patented bearing and mechanical seal cartridges

Main Applications

- Wastewater treatment plants
- Biogas plants
- Agriculture
- Slaughterhouses and recycling plants
- Food waste
- Crushing of foreign matter, such as plastic, bags and bottles as well as shoes, textiles, skins and hair, aluminum cans, tin scrap and lids



N.Mac[®] 50I

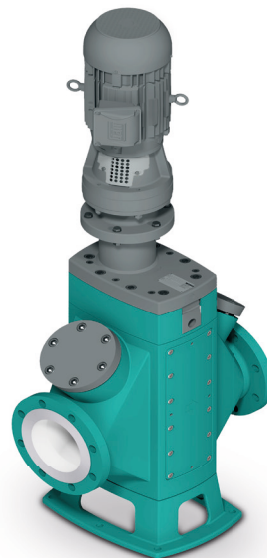

N.Mac[®] 150I

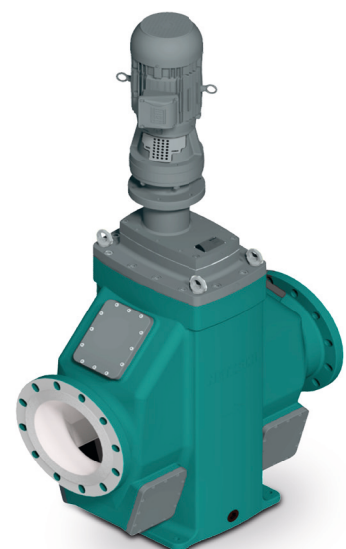

N.Mac[®] 350I

INLINE INSTALLATION

Cutter cartridges

Specific cutter geometries for each type of solids facilitate the particle reduction process. To reach the required particle size the different cutters with 3 to 11 teeth may be combined accordingly.

Wear resistance

The cutters are thermally hardened to increase resistance and sharpness assuring reliable grinding of the toughest solids.

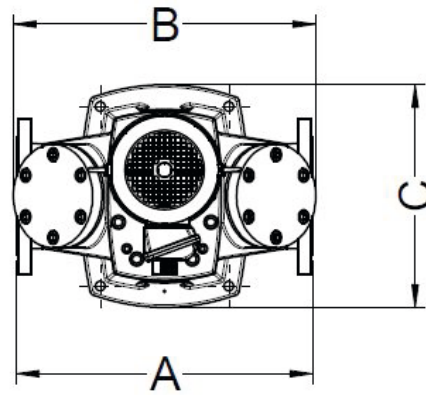
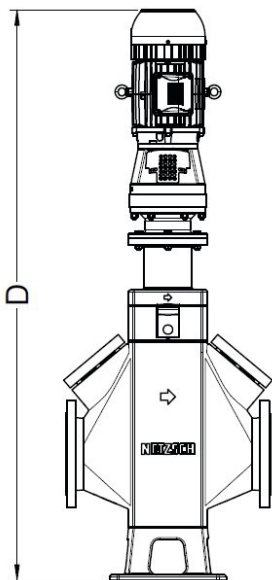
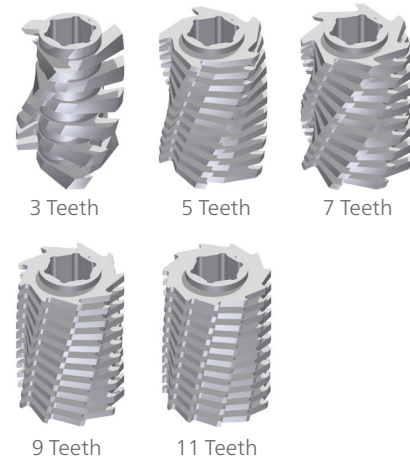

Flow rates und dimensions

Sizes	Flow rate (m ³ /h)	Pressure drop (bar)	Maximum pressure (bar)	Approximate weight (kg)	Flanges (ANSI/DIN)	Dimensions (mm)			
						A	B	C	D
N.Mac® 50I	50	0,05	6,0	220	150	340	350	445	1130
N.Mac® 150I	150	0,12	6,0	360	150	545	555	410	1525
N.Mac® 350I	350	0,08	6,0	780	250	830	830	425	1780

N.Mac[®] Channel

DOUBLE SHAFT GRINDER FOR

Also in the channel version, the N.Mac[®] double-shaft grinder is ideal for fragmenting large and solid particles in liquid media and suits various applications such as wastewater treatment or grinding of food and fruit scraps. This housing design allows installation in sewers to avoid blockages and by crushing foreign substances.

Features

- Double shaft technology for size reduction of solid particles
- Energy efficient motors, from 2.2 - 4 kW
- Low speed of the cutters at high torque
- Standard cutter configuration with 7/7 teeth
- Optional control unit with reverse direction of rotation in case of blockages

Your benefits

- Shock absorption technology
- Mechanical seal with quench
- Optional cleaning comb for fibrous materials
- Patented side rails
- Cutting devices in cartridge system
- Patented bearing and mechanical seal cartridges

Main applications

- Wastewater treatment plants
- Slaughterhouses and recycling centers
- Food waste
- Crushing of foreign matter such as plastic, bags and bottles as well as shoes, textiles, skins and hair, aluminum cans, tin scrap and lids



N.Mac[®] 50C



N.Mac[®] 120C

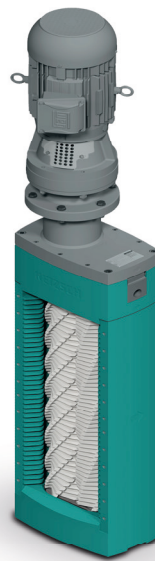

N.Mac[®] 250C



N.Mac[®] 400C

CHANNEL INSTALLATION

Cutters

Specific cutter geometries for each type of solids facilitate the particle reduction process. To reach the required particle size the different cutters with 3 to 11 teeth may be combined accordingly.

Wear resistance

The cutters are thermally hardened to increase resistance and sharpness assuring reliable grinding of the toughest solids.

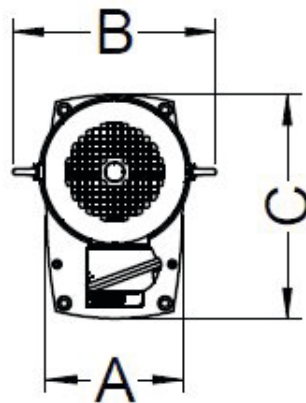
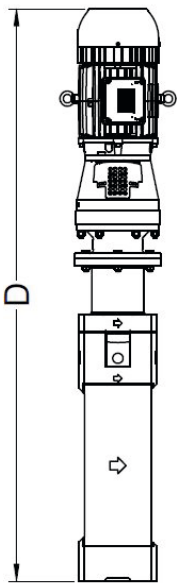
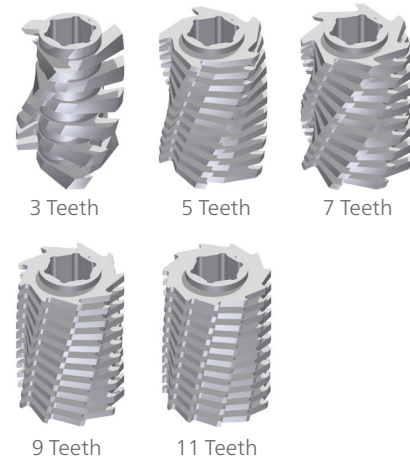

Flow rates und dimensions

Sizes	Flow rate (m ³ /h)	Approximate weight (kg)	Dimensions (mm)			
			A	B	C	D
N.Mac® 50C	50	170	190	290	310	1225
N.Mac® 120C	120	200	190	290	310	1400
N.Mac® 250C	250	260	190	290	310	1750
N.Mac® 400C	400	320	190	290	310	2095

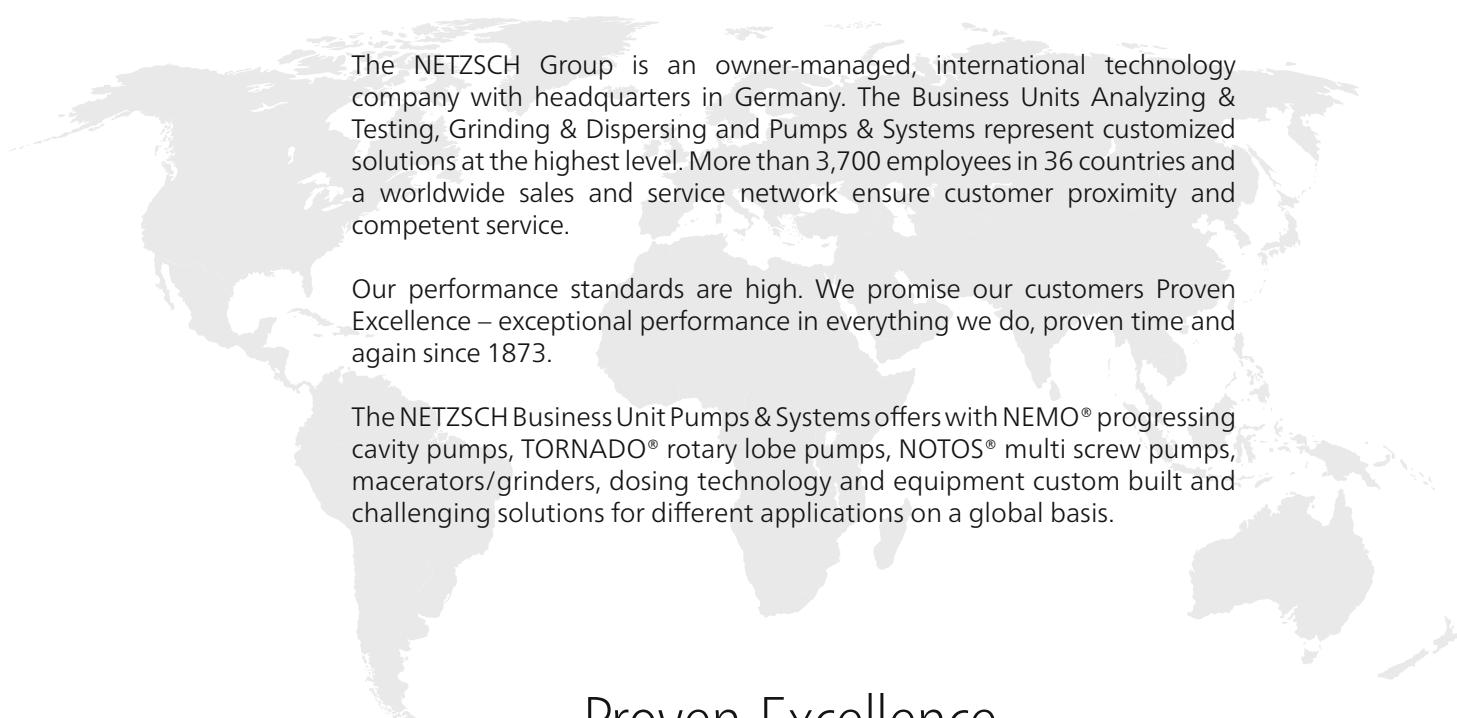

The NETZSCH Group is an owner-managed, international technology company with headquarters in Germany. The Business Units Analyzing & Testing, Grinding & Dispersing and Pumps & Systems represent customized solutions at the highest level. More than 3,700 employees in 36 countries and a worldwide sales and service network ensure customer proximity and competent service.

Our performance standards are high. We promise our customers Proven Excellence – exceptional performance in everything we do, proven time and again since 1873.

The NETZSCH Business Unit Pumps & Systems offers with NEMO® progressing cavity pumps, TORNADO® rotary lobe pumps, NOTOS® multi screw pumps, macerators/grinders, dosing technology and equipment custom built and challenging solutions for different applications on a global basis.

Proven Excellence. ■

NETZSCH Pumpen & Systeme GmbH
Geretsrieder Straße 1
84478 Waldkraiburg
Germany
Tel.: +49 8638 63-0
info.nps@netzsch.com

BLUECOMPETENCE
Alliance Member

Partner der Nachhaltigkeitsinitiative
des Maschinen- und Anlagenbaus

NETZSCH®

www.netzsch.com