

Solids handling pumps KOS

For coarse grain high density solids and high pressure applications

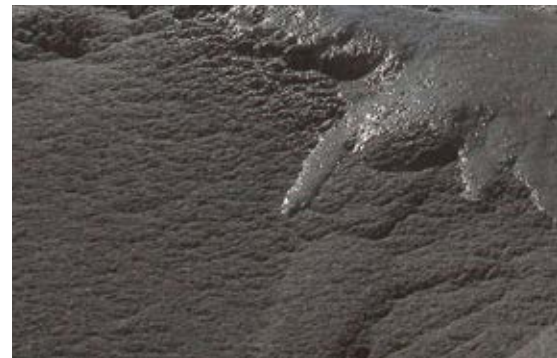

Putzmeister

Industrial Technology

Mining · Energy · Environment · Oil & Gas

Solids handling pumps KOS

Oil-hydraulic double-piston pump with S-transfer tube

In the KOS series, the intake (for connection of the delivery line) and the delivery cylinders are connected by an S-transfer tube. This enables a freeflowing conveyance of the material without the use of valves. Foreign bodies up to 2/3 of the size of the discharge outlet can be conveyed without any issue.

The KOS pump is particularly suitable for conveying highly viscous sludges and other material with a high proportion of extraneous material. The main fields of application of the KOS are with materials which present the most extreme requirements, such as dewatered sludges containing solids, oil sludges, high-viscosity solids and so on.

For extreme applications, a wide range of task-specific components and functions are available from Putzmeister. The pump's simple design and the few wear parts offers a very robust, low maintenance pump with low operating costs.



Features and advantages

- For conveying coarse sludges or slurries with a high grain-size content
- Low maintenance and wear due to fewer moving parts
- Less suction resistance thanks to larger inlet permitting constant freeflow of the material
- Continuous material flow due to the large discharge diameter
- The hydraulic circuit of the S-tube does not come in contact with the material being pumped
- Reliable isolation of hydraulic circuit from the material, even when inadequately maintained
- Output up to 400 m³/h
- Delivery pressures up to 150 bar

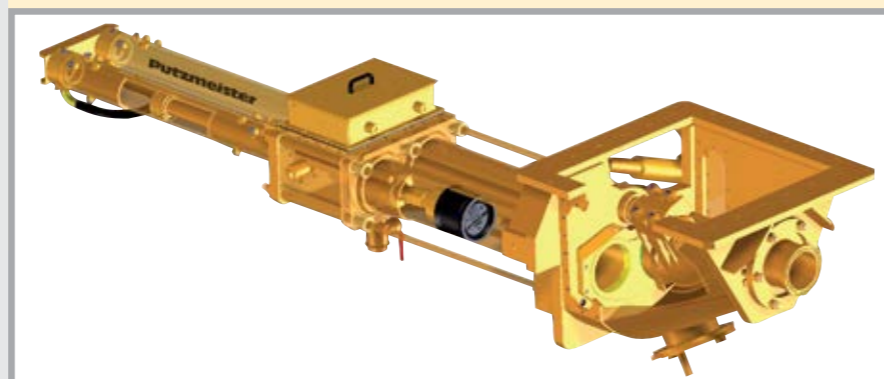

Redundant transport of fly and bottom ash from a power station

The main field of application is thus for materials with most extreme requirements, for example:

- Highly dewatered sewage sludges
- Sewage sludges with percentages of foreign bodies, for example when handling external sludges
- Fly and bottom ash from power stations
- Tailings from mining and tunnelling
- Oil sludges with percentages of foreign bodies
- Bio waste and other waste
- Chemical and organic high density solids with highest viscosity

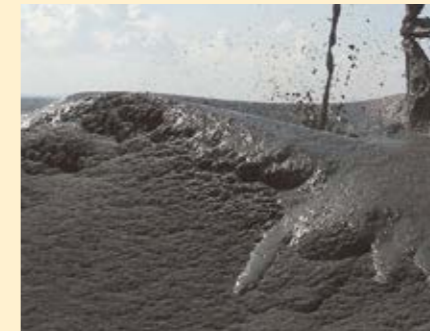

Tailings transport in mining



Fly and bottom ash



Sewage sludge from filter press and centrifuges



Bio-waste and special waste

The powerful solids handling pumps with S-transfer tube

The S-transfer tube

There are different variations in shape and diameter of the S-transfer tube. It can thus be adapted to the respective operating conditions. The range of thin, watery suspensions to thick, compact sludges is no problem for the S-transfer tube.

Numerous successful applications and satisfied customers in all fields of high density solids conveying, prove the reliability and efficiency of this system. Many impressive world records have thereby been set under the most difficult of conditions.

Type	Inside Ø	
	Inlet mm	Outlet mm
S 1812V	180	120
S 2015V	200	150
S 2018V	200	180
S 2318V	230	180
S 3025V	300	250
S 5030V	500	300

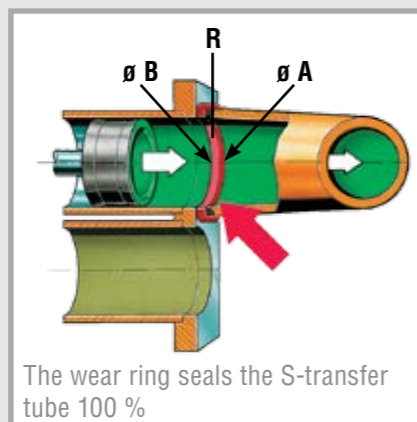
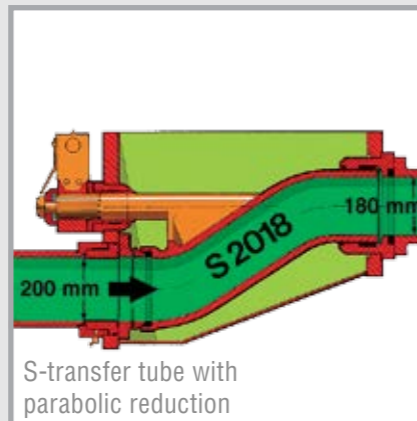

The automatic ring

It is especially difficult to seal between the S-pipe and delivery line when conveying at high pressure or when conveying abrasive material.

The Putzmeister solution here: The automatic ring.

Under pressure, wear ring R is pressed against wear plate B as $\varnothing A$ is larger than $\varnothing B$. The S-pipe slides back within R and is sealed by the O-ring. The higher the pressure, the more sealproof the system. This ring automatically compensates for the switch-over wear of the transfer tube during operation.

It doesn't matter whether the material is fine or coarse, the patented automatic ring always seals well – when new it even seals hermetically against water. The special advantage here: Thanks to the special design, only one sealing point is required. Adjustment of tension and additional wear compensation are possible.

The prepresser unit

For stiff media which cannot be drawn in as they are, prepresser units with self-cleaning screw conveyors have to be installed on the intake side.

The conveyed product in the hopper is intensively kneaded and mixed in the screw conveyors and then forced in the cylinders to achieve a high level of volumetric efficiency. This enables even compact, moist and almost dry waste to be pumped into the cylinders.

The design of the screw conveyors determines the mixing intensity. The waste continues to be mixed in the pump and delivery line due to the turbulent flow. The prepresser unit is modular and can be adapted to best suit each individual application.

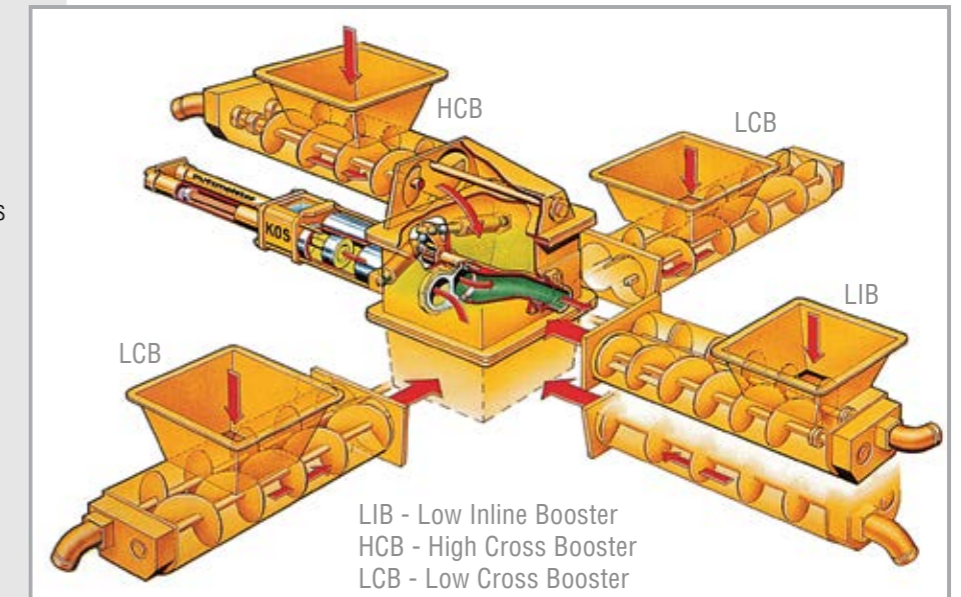

The power pack

The output and pressure can be adjusted to suit various applications thanks to the hydraulic drive. Both are controlled via the control cabinet or from a higher level control room.

The electric and diesel power packs are between 5.5 and 1800 kilowatts, more can be achieved under certain circumstances with special requirements. The machine is delivered with an open (VHS-EU) or closed hydraulic circuit (FFHE) depending on the volume of fluid required. For problem-free operation, all essential information (hydraulic fluid temperature, pressure, level of filter contamination and motor speed) is displayed and recorded as required.

The power packs can be optionally equipped with acoustic enclosures.

The system is controlled by the Putzmeister Operation Panel (POP).



Control cabinet with Operation Panel



CI power pack with acoustic enclosure (optional)

The S-transfer tube offers decisive advantages during operation in conjunction with the automatic ring:

- Favourable flow conditions
- High cylinder filling rate
- Low wear
- Long service life
- Easy-to-clean
- Especially compression-proof even with a high percentage of solids
- Quiet and exact pumping characteristic
- Maintenance-friendly thanks to screwed-on changeover shaft

Accessories for custom design and equipment of your system

KOS Technical data

Delivery lines

Delivery lines in industry must especially be safe over a long period of operation (24/7). The pressure resistance with pulsating load is one particular criteria when designing the delivery line. These can be designed in DIN, SK and ZX with different flange and coupling systems. The Putzmeister SK and ZX systems have proved themselves worthy for abrasive and non-abrasive materials. They have a clamp coupling for easy installation and removal.

ZX delivery lines are used in sewage treatment works, in waste recycling, in coal-fired power plants, waters desludging, in mining and other numerous special applications. Depending on the application, the design, material and the surface treatment can be modified in order to be ideally adapted to the pump and material to be conveyed.



Ball, gate or diversion valves

Delivery line components must be designed regarding the dynamic loads and characteristics of the media. Ball valves for example are therefore equipped with stronger shaft shanks and flush connections.

Gate and diversion valves are essential when multiple delivery lines have to be installed. Thus, the material located in the pipeline after the pump can be diverted through a gate valve to other routes such as a thermal dryer or intermediate storage.

Gate valves are hydraulically operated. For a faster switch, it is suggested to use a power pack of at least 7.5 kW. The valve housing is sealed with hardened sealing rings, that are pressed against the moving blade of the valve.

A wide range of application specific components and functions are available for extreme operation, e.g.

- Reinforced S-pipes and S-pipe piston for shearing off the foreign bodies
- Automatic reverse pumping functions for preventing and automatically removing blockages
- Mixer paddles in the feeding device for homogenizing the materials
- Agitators in the suction housing for extremely stiff and inhomogeneous materials
- Different materials for the machine elements for handling abrasive and aggressive media (i.e. stainless steel in the food industry or salt mining)
- Different types of feeding devices on the suction side
- Receiver container with or without agitator
- Vibration damper for the delivery system
- Gate and distribution valves
- Boundary layer lubricant injection station
- Scraper pig gates for delivery line cleaning

Type	Output*		Permanent delivery pressure**		Delivery cylinder Ø		Delivery cylinder length		Cylinder-volume per stroke		Length (L)		Width (W)		Height (H)		Weight approx.	
	m³/h	gpm	bar	psi	mm	in	mm	in	l	gal	mm	in	mm	in	mm	in	kg	lb
KOS 740	23	101.2	60	870	150	5.91	700	27.56	11.4	3.01	3042	119.76	920	36.22	670	26.38	1000	2205
KOS 1030	16	70.4	90	1305	120	4.72	1000	39.37	10.5	2.77	3220	126.77	920	36.22	910	35.83	1200	2646
KOS 1040 HP	25	110	100	1450	150	5.91	1000	39.37	15.6	4.12	4100	161.42	1100	43.31	1072	42.20	2500	5512
KOS 1050	36	158.4	60	870	180	7.09	1000	39.37	22.5	5.94	4100	161.42	1100	43.31	1072	42.20	2500	5512
KOS 1050 HP	36	158.4	80	1160	180	7.09	1000	39.37	22.3	5.89	4100	161.42	1100	43.31	1072	42.20	2800	6173
KOS 1070	60	264	45	652.5	230	9.06	1000	39.37	36.8	9.72	4100	161.42	1100	43.31	1072	42.20	2800	6173
KOS 1070 HP	60	264	70	1015	230	9.06	1000	39.37	36.4	9.62	4100	161.42	1100	43.31	1072	42.20	3000	6614
KOS 1080 HP	90	396	60	870	280	11.02	1000	39.37	53.9	14.24	4500	177.17	1100	43.31	1072	42.20	3200	7055
KOS 1080 HPS	85	374	70	1015	280	11.02	1000	39.37	45.6	12.05	4500	177.17	1100	43.31	1072	42.20	3300	7275
KOS 2180 HP	100	440	70	1015	280	11.02	2100	82.68	113.3	29.93	6700	263.78	1200	47.24	1072	42.20	5000	11023
KOS 2180 HPS	100	440	120	1740	280	11.02	2100	82.68	113.3	29.93	6700	263.78	1200	47.24	1072	42.20	7500	16535
KOS 25100	160	704	35	507.5	360	14.17	2500	98.43	224.6	59.34	8140	320.47	1700	66.93	1540	60.63	8500	18739
KOS 25100 HP	160	704	100	1450	360	14.17	2500	98.43	216.4	57.17	8140	320.47	2150	84.65	1540	60.63	10700	23589
KOS 25100 HPS	160	704	150	2175	360	14.17	2500	98.43	223.9	59.15	8015	315.55	2246	88.43	1790	70.47	10700	23589
KOS 25150 HP	250	1100	100	1450	450	17.72	2500	98.43	349.9	92.44	8758	344.80	2246	88.43	1990	78.35	19000	41887
KOS 25200	385	1694	30	435	560	22.05	2500	98.43	523.6	138.34	8950	352.36	3112	122.52	2088	82.20	22600	49824
KOS 25200 HP	385	1694	100	1450	560	22.05	2500	98.43	523.6	138.34	9262	364.65	2800	110.24	2419	95.24	32000	70547



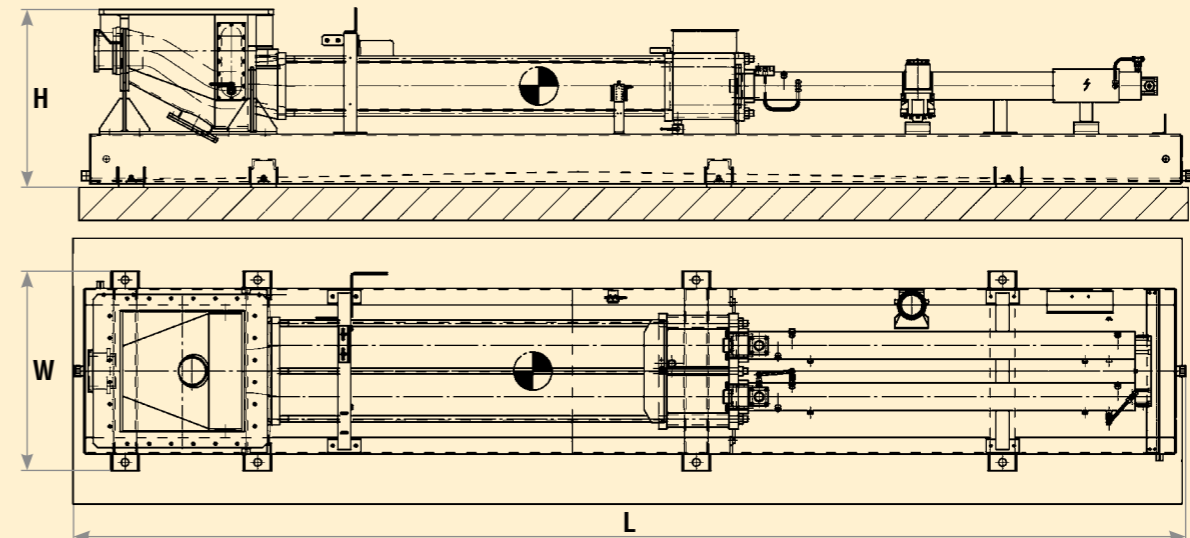

The values provided above are to be viewed as guideline values only and may alter depending on machine applications. Please request detailed quotation drawings.
 * geometric, rounded
 ** maximum theoretical

Conversions:
 1 bar = 14.5 psi
 1 inch = 25.4 mm
 1 US Gallon = 3.785 l
 1 kg = 2.2046 lb

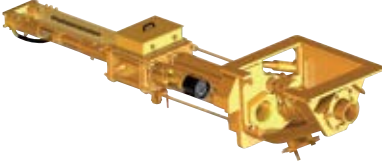

KOS solids pump, exemplary illustration

The right pump for every application

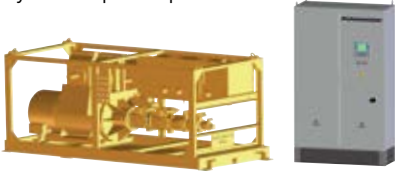
	Application	Output	Pressure
 <p>KOS series S-tube pump</p>	Coarse sludges or slurries with a high proportion of solids, up to 80 mm grain size	10 – 400 m ³ /h (440 – 1760 gpm)	up to 150 bar (2176 psi)
 <p>HSP series seat valve pump</p>	Fine grained sludges or slurries	10 – 400 m ³ /h (440 – 1760 gpm)	up to 150 bar (2176 psi)
 <p>KOV series ball valve pump</p>	Fine grained pastes	0 – 70 m ³ /h (0 – 308 gpm)	up to 80 bar (1160 psi)
 <p>EKO series single piston pump</p>	Large-sized and coarse particles, extremely stiff material	up to 14 m ³ /h (61.6 gpm)	up to 100 bar (1450 psi)
 <p>Hydraulic power pack and control cabinet</p>	All Putzmeister pumps are driven by a hydraulic power pack	Performance:	5.5 – 1800 kW

Right to make technical amendments reserved. Illustrations partly show optional equipment. © by Putzmeister Solid Pumps GmbH 2015. All rights reserved. Printed in Germany (215035C) IP 1082-8 EN



Putzmeister Solid Pumps GmbH
 Max-Eyth-Straße 10 · 72631 Aichtal/Germany
 P.O. Box 2152 · 72629 Aichtal/Germany
 Phone +49 (7127) 599-500 · Fax +49 (7127) 599-988
 psp@pmw.de · www.pmsolid.com

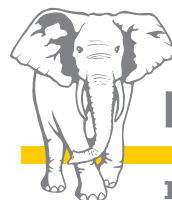

Putzmeister

Industrial Technology
 Mining · Energy · Environment · Oil & Gas